



TEREX®

GTH-842

Telehandler

OPERATING WEIGHT	21,500 lbs (9,752 kg)
NET ENGINE POWER	99 or 100 hp (73.8 or 74.6 kW)
MAXIMUM LIFT CAPACITY	8,000 lbs (3,629 kg)
MAXIMUM LIFT HEIGHT	42' (12.8 m)



TELEHANDLER GTH-842

Specifications

Performance

Operating weight with forks	21,500 lbs (9,752 kg)
Outside turn radius	14' 9" (4.50 m)
Maximum drawbar pull	19,200 lbs (8,709 kg)
Maximum lifting height	42' (12.8 m)
Reach at maximum height	3' (0.91 m)
Maximum forward reach	25' (7.62 m)
Maximum lift capacity	8,000 lbs (3,629 kg)
Lift capacity at maximum height	6,000 lbs (2,722 kg)
Lift capacity at maximum reach	2,000 lbs (907 kg)

Steering

Power assisted steering

Three steering modes: 2-wheel, 4-wheel coordinated, and 4-wheel crab

Engine

John Deere 4045TF270 / Deutz BF4 2012 / Perkins 1104-44T

4 cylinders turbocharged diesel

Power @ 2,500 rpm 99 hp (73.8 kW) / 100 hp (74.6 kW)

Tier II Compliant

Transmission

3 speed Powershift/torque converter

4-wheel drive

Front axle differential lock (std)

Maximum speed 18 mph (29 km/h)

Brakes

Inboard multiple wet disc

Telehandler GTH-842

Specifications

Sway Control - Frame Leveling	
Circuit isolated cylinders, 10 degrees either side of center	
Frame Stabilizer	
Twin rear axle lock cylinders	
Hydraulic System	
Pressure compensated hydraulic system	
Variable-displacement axial piston pump	
10 Micron filtration	
Auxiliary hydraulic circuit	3-7 gpm (11-26 Lpm) / 3,000 psi (207 bar)
Tank Capacities	
Fuel tank capacity	30 gal (114 L)
Hydraulic tank capacity	34 gal (129 L)
Hydraulic system capacity (w/tank)	50 gal (189 L)
Tires	
13 x 24 in - 12 ply, calcium chloride filled rock lug tires	
13 x 24 in - 12 ply, foam-filled rock lug tires	
13 x 24 in - 12 ply, foam-filled rough terrain tires	
Forks and Attachment Holder Plate	
Length	48" (1.22 m)
Fork cross-section	2" x 4" (51 mm x 101 mm)
Attachments and Fork Options	
Cubing tines	Set of four
Pallet forks	60" & 72" (1.52 & 1.83 m)
Full taper forks	60" (1.52 m)
Lumber forks	60" (1.52 m)
Wide fork frames	60" & 72" (1.52 & 1.83 m)
Rotating fork frames	48", 60", & 72" (1.22, 1.52, & 1.83 m)
45° Swing fork frames	60" & 72" (1.52 & 1.83 m)
Rubbish bucket	1 yd ³ (0.76 m ³)
Variable reach truss boom	
Quick switch attachment	

Operating Cab

Structure conforms to ISO 3471 (ROPS) and ISO 3449 (FOPS)

Optional enclosed cab, heater and air conditioning

Standards Compliance

ASME B 56.6, ISO 3471, ISO 3449

Dimensions with Boom Retracted and Down

Overall L x W x H	20' x 8' 6" x 8' 11" (6.10 x 2.59 x 2.72 m)
Wheelbase	10' 10" (3.30 m)
Turning radius, outside (4WS)	14' 9" (4.50 m)
Ground clearance (center)	1' 5" (0.43 m)

Working Ranges and Lift Capacities

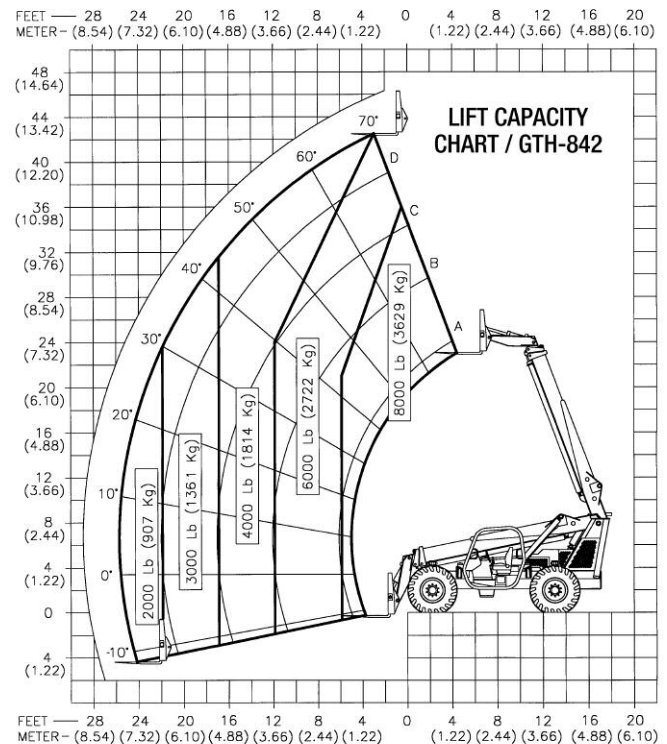

Terex Construction Americas (SALES)

8800 Rostin Road
Southaven, MS 38671
USA
TEL 662-393-1800 SALES 866-837-3923
FAX 662-393-1700 EMAIL sales@terexca.com
WEB terex.com

Genie Industries, Inc. (WARRANTY, PARTS, SERVICE, & SUPPORT)

A Terex Company
18340 NE 76th Street
Redmond, WA 98073
PARTS & TECH SUPPORT 877-367-5606
FAX 888-274-6192
WEB genieindustries.com

For more information, product demonstration, or details on purchase, lease and rental plans, please contact your local Terex dealer.